

**ECART**

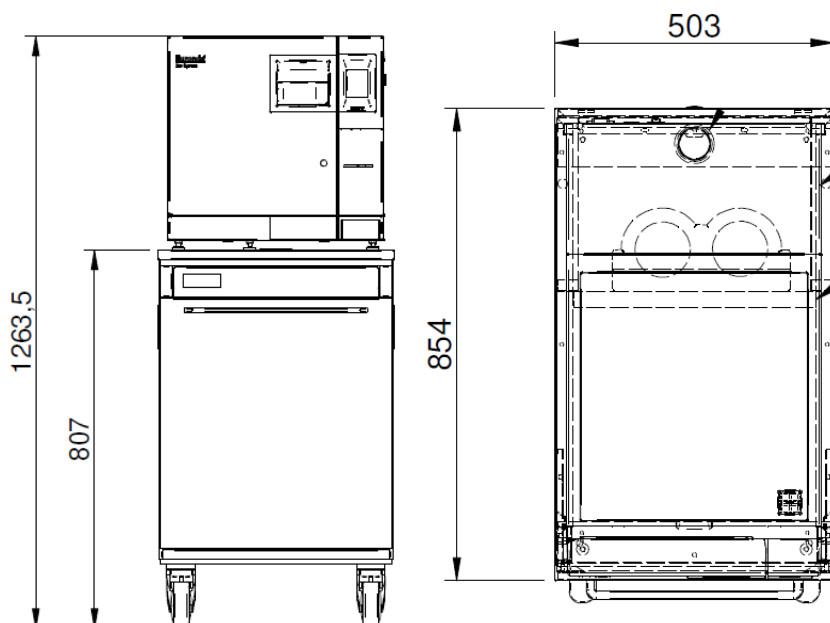
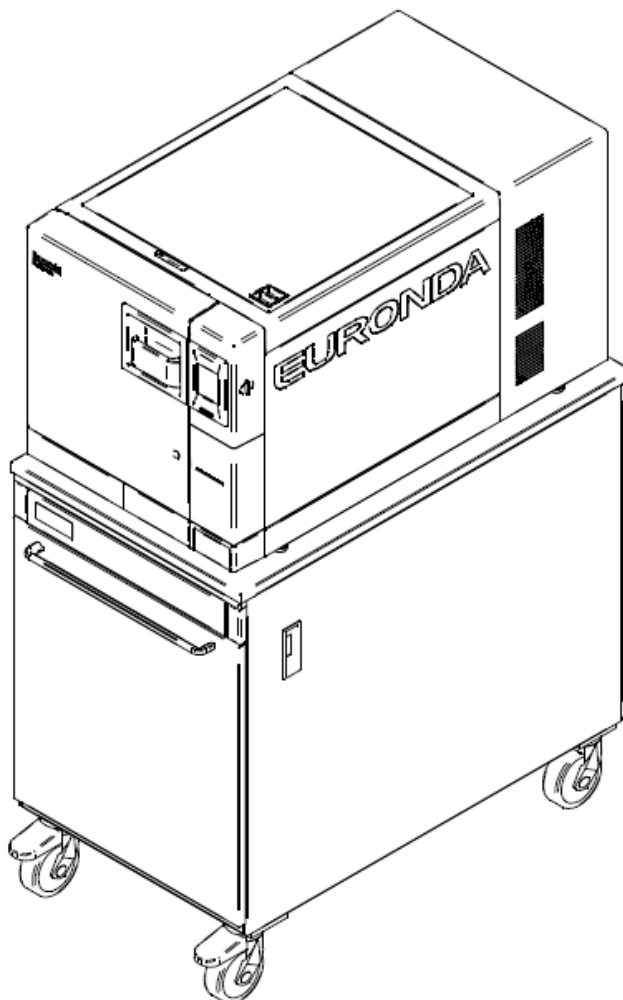

Destinazione d'uso: Intended use:	Servomobile per autoclave Cart for autoclave
Compatibile con: Compatible with:	EXL
Materiali: Materials:	Acciaio Iron
Peso netto: Net weight:	52 Kg
Colore: Colour:	Bianco White
Peso totale dell'imballo Total weight of packaging	62,5 Kg
Dimensioni di ingombro dell'imballo Overall dimensions of packaging	Lunghezza/Length: 108 cm Larghezza/Width: 63 cm Altezza/Height: 98 cm